



Precision Plumbing Products

"Specify with Confidence - Install with Pride"

Fluid Hammer Arrestors MM-500ASTH 1/2" FMIP

www.pppinc.net

- 1.) Flush line thoroughly prior to installation.
- 2.) Apply thread seal tape to threads of stub out. Do not use pipe dope. Use of pipe dope will make null and void product warranty.
- 3.) Thread angle stop onto stubout.
- 4.) Attach supply line (not provided) to angle stop and to toilet tank.
- 5.) Open angle stop by turning handle counter clockwise.

Part No:
MM-500 ASTH

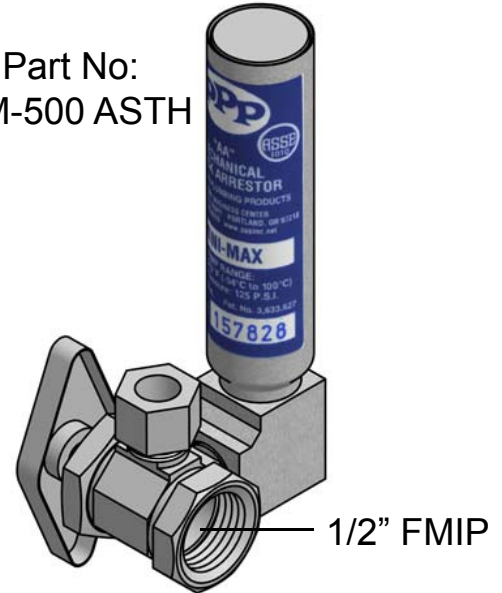

1/2" FMIP

Precision Plumbing Products of Portland, Oregon (USA) warrants our manufactured products to be free from defects and workmanship under normal use and service. The sole and exclusive remedy for our manufactured products that do not conform to this limited and express warranty and our sole obligation under this limited and express warranty is to replace the defective part or product during the three year period after original installation. This warranty excludes any parts or products that are modified or improperly installed or installed where PH levels, chemical conditions or electrolysis prematurely degrade the product. We specifically disclaim any warranties or responsibility for defects due to quality, material, dimensional tolerances or quality control of any fitting or other third party supplied parts or components. **EXCLUSIONS OF ALL OTHER WARRANTIES INCLUDING IMPLIED WARRANTIES:** All other warranties, including the implied warranties of **MERCHANTABILITY** and fitness for a particular purpose, are **EXCLUDED** from this transaction and shall not apply to goods sold by us. The above warranties are in lieu of all other warranties and representations, express or implied, and all other obligations or liabilities on our part. We shall not be liable for consequential damages, loss of profit, interruption of business or any other special, incidental, or punitive damages suffered or sustained by Customer. Any part or products being returned under this warranty must have prior authorization by us. Any part or product received by us without a return of goods authorization will be returned to the shipper. All returned merchandise must be prepaid by shipper. Our personnel, including salespeople, as well as independent distributors and sales agents may have made oral statements about our products. Those statements are not warranties by us and should not be relied on by the buyer/customer/user. If you use this product you are agreeing to this warranty contract between us. This writing constitutes the final expression of the parties and is the complete and exclusive statement of that contract for warranties.

Precision Plumbing Products

Division of JL Industries, Inc.



802 SE 199th Avenue
Portland, Oregon 97233

T (503) 256-4010
F (503) 253-8165

www.pppinc.net

JL Industries, Inc.



MI-WHA-07 Rev 02/10